



Original

Operating Instructions

VERSION 1.9

BDC-1114PM / BDC-1114PH / BDC-1114PH CA ASBESTOS



Original Operating Instructions

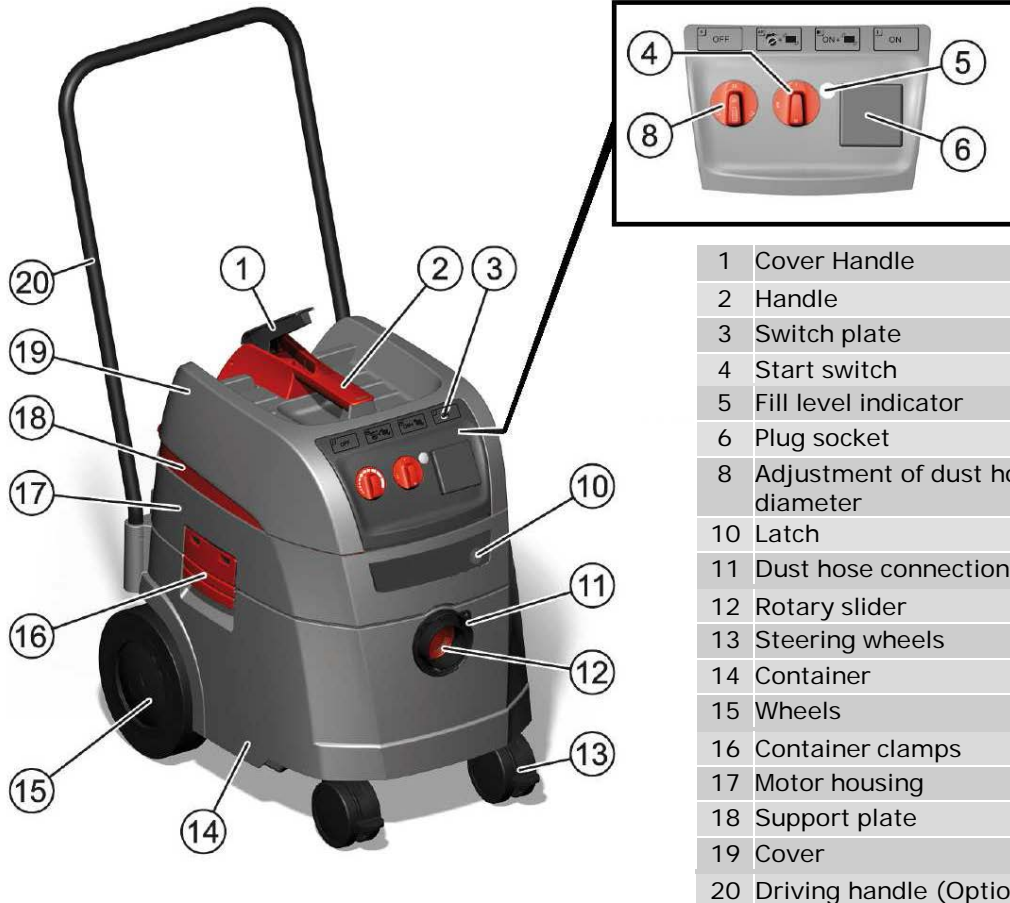

- 1 Cover Handle
- 2 Handle
- 3 Switch plate
- 4 Start switch
- 5 Fill level indicator
- 6 Plug socket
- 8 Adjustment of dust hose diameter
- 10 Latch
- 11 Dust hose connection
- 12 Rotary slider
- 13 Steering wheels
- 14 Container
- 15 Wheels
- 16 Container clamps
- 17 Motor housing
- 18 Support plate
- 19 Cover
- 20 Driving handle (Option)



A Driving handle	ES 012834	F Accessory storage	ES 512723
B Suction hose Ø35 mm	ES 413235	G PE emptying and disposal bag	E06260 (5x)
C M -class filter Set of 2 cartridges M/535 777	ES 423159	H PE bag for ASBESTOS	ES 430249 (5x)
H -class filter cartridge Set of 2 cartridges H/HEPA 551029	ES 428956	I Rubber sleeve (Option) Ø 4 - 3.5 - 3 - 2.5 mm	ES 430669
D Motor protection filter	ES 408040	J Connector for Blastrac Ø 51 mm hose	ES 529752
E Crevice nozzle (Option)	ES 430690	K Blastrac PU dust hose Ø51 mm (Option)	004583
		L Fleece filter-bag (M-class)	ES 435305

Introduction

It is important that all persons who are working or maintaining this machine read the manual carefully and understand it fully. Keep this manual near to the machine, so it can always be consulted. In case you sell the unit, hand it on to the next owner.

This machine is designed for industrial use by professionals. Only authorized and trained personnel may operate this machine. This machine is not intended for use by persons (including children) with reduced physical, sensory or mental capabilities, or lack of experience and knowledge.

Machine description

The Blastrac dust collector BDC-1114 is intended for industrial use in combination with Blastrac machines. It can be used for dry or wet cleaning.

The BDC-1114PM is designed for usage in conditions according to classification **M** (see below).

The BDC-1114PH is designed for usage in conditions according to classification **H** (see below).

The BDC-1114PH CA ASBESTOS is designed for usage in **Asbestos** removal.

Classification acc. standard EN 60335-2-69 – Annexe AA		
Type	Class	Designation
BDC-1114PM	M	Class M vacuum devices are suitable for aspiration/clearing of dry, non-combustible dusts, non-combustible liquids, wood dusts and hazardous dusts with workplace limit values of $\geq 0.1 \text{ mg/m}^3$.
BDC-1114PH & PH CA ASBESTOS	H	Class H vacuum devices are suitable for aspiration/clearing of dry, non-combustible dusts, carcinogenic and pathogenic particles as well as non-combustible liquids, wood dusts and toxic dusts with workplace limit values of $< 0.1 \text{ mg/m}^3$.

Dust emissions into the environment	
Class	Value of performance
L	Retains at least 99 % of particles measuring $\geq 3 \mu\text{m}$
M	Retains at least 99,9 % of particles measuring $\geq 3 \mu\text{m}$
H	Retains at least 99,995 % of particles measuring $\geq 3 \mu\text{m}$

The BDC-1114 is available in 3 versions :

- ⓪ 230 Volt 50/60hz version
- ⓪ 110 Volt 50Hz version
- ⓪ 120 Volt 60Hz version

All versions dust collectors are complete with an electronic filter cleaner. It can be used in automatic mode for a constant high suction power.

Application

The BDC-1114 is especially designed to be used in combination with Blastrac hand grinders, hand scarifiers, hand blaster machines and some other types of Blastrac machines.

But the BDC-1114 is also a perfect dust collector for all other kind of hand equipment and machines.

Contact Blastrac B.V. for the correct execution and combinations.

Labels: The following labels are placed on the machine.



Type plate on all classes machines

Descriptions :

- ⓪ Data regarding power supply.
- ⓪ IP enclosures
- ⓪ Serial number
- ⓪ CE marking



Class M appliances.

WARNING: This unit contains hazardous dust. Emptying and maintenance, including the removal of the dust bag, may only be carried out by someone who is familiar with the unit and wearing suitable protective gear. Do not switch on the unit until the complete filter system has been installed and the function of the volume-flow control has been tested.



Class H appliances.

Full text :

“WARNING: This appliance contains dust hazardous to health. Emptying and maintenance operations, including removal of the **dust collection means**, must only be carried out by authorised personnel wearing suitable personal protection. Do not operate without the full filtration system fitted. ”

Class H / ASBESTOS appliances.

Full text :

“WARNING: This appliance contains dust hazardous to health. Emptying and maintenance operations, including removal of the **dust collection means**, must only be carried out by authorised personnel wearing suitable personal protection. Do not operate without the full filtration system fitted. ”



Extra type plate for ASBESTOS

Descriptions :

- ⓪ Data regarding airflow
- ⓪ IP enclosures
- ⓪ Weight
- ⓪ Sound data



Filter cartridges



M/535 777 - Filter cartridge dust class M

Set of 2 cartridges.
 Art.Nr. M/535 777 - Order Nr. ES 423159



H/HEPA 551029 -Filter cartridge dust class H

Set of 2 cartridges with test certificates.
 Art.Nr. H/HEPA 551029 – Order Nr. ES 428956

Regulations regarding asbestos

- The H-class filter cartridges are mandatory.
- Each Asbestos vacuum cleaner comes with a PE emptying and disposal bags for ASBESTOS it is mandatory to use this when working with asbestos.
- The PE bags must be fitted as described in chapter 7.4 and disposed of as described in chapter 7.2.
- Check the local regulations on maintenance and inspection intervals for asbestos vacuum cleaners, but at least once per year the machine should be checked by professionals and get a full overhaul.
- Preferably use the machine for dry asbestos cleaning.
- Check and obey the local regulations regarding the handling and disposal of the contaminated waste.
- All parts of the dust collector must be considered as contaminated when they are removed from the hazardous zone and appropriate actions must be taken to prevent dust from dispersing.
- Blastrac B.V. cannot be held responsible for the misuse and /or failure to comply with the rules by the user.
- In areas with asbestos fiber concentrations respirators with particulate filter P3 must be worn:
 1. Particle-filtering half masks FFP3 for brief activities of a maximum of two hours per shift,
 2. Half Masks with P3 filter for prolonged activities,
 3. Mask with blowers and particle filters TM2P or higher respirators.



General requirements

If there is a possibility that asbestos fibres are released, they shall be collected at the exit point or point of origin and then be disposed of without risk to human and environment according to the best technical measures available. If complete capture is not possible, additional ventilation measures are to be taken according to the best technical measures available.

At the end of work, the tools including exhaust ducts, work equipment and the work area must be carefully cleaned.

With asbestos fibres contaminated objects that cannot be cleaned must be moistened and removed properly. After cleaning the work area must be adequately ventilated.

Particular requirements for industrial vacuum cleaners and dust collectors

Extracted air must be guided or cleaned in a way that asbestos fibres are not released into the breathing air of other workers. The dust obtained must be transported in dustproof containers. Decanting is not permitted.

The asbestos fibre content in the exhausted air may not exceed 1000 Fibres / m³.

This machine is a type-approved industrial vacuum cleaner or dust collector and meets this criterion.

It must be ensured that the working area is supplied with sufficient outdoor air (fresh air).

For activities involving materials containing asbestos, a recirculation of purified air in the work area is not allowed.

The following activities with this industrial vacuum cleaner or dust collector and recirculation of purified air are permitted:

1. Activities involving low exposure according to TRGS 519, Number 2.8 confined spaces or small-scale work to TRGS 519, Section 2.10,
2. Cleaning.

This industrial vacuum cleaner or dust collector is to be serviced, as required, but at least once a year, and if necessary, repaired, by a competent person (see qualification TRGS 519, Number 5.3, paragraph 2) to check or by a maintenance company. The test result is provided on request.

In the black area used industrial vacuum cleaners and dust collectors may only be operated in the white area after complete cleaning, including the motor housing.

For engines with bypass cooling also the cooling air ducts have to be cleaned.

1 Safety advice



DANGER! – WARNING!

- ▶ Danger of suffocation
 - Keep packaging material such as plastic bags away from children.
- ▶ Never stand or sit upon the vacuum device.
- ▶ Particular caution is advised when ascending stairs.
Pay attention to standing safely.
- ▶ Do not pull the suction hose and connection line over sharp edges, kink it or shut it.
- ▶ Always lay the suction hose and connection line so that nobody may trip over them.
- ▶ In case of any leakage of foam or liquid, immediately switch off the vacuum device.
- ▶ Always keep the inside of the lid dry.
- ▶ Do not start the vacuum device including its accessories if:
 - the vacuum device shows detectable damage (fissures/cracks);
 - the power connection line is defective or shows fissuring or ageing; or
 - any invisible defect is suspected (after a fall).
- ▶ Do not allow the rotating brushes to get into contact with the power connection line.
- ▶ Do not operate the vacuum device where there is danger of explosions.
- ▶ Keep the vacuum device away from inflammable gases and substances.
- ▶ Do not aspirate any combustible or explosive solvents, materials soaked in solvents, explosive dusts, liquids such as petrol, oil, alcohol, diluents or materials hotter than 60 °C (140 °F).
- ▷▷ Otherwise there will be danger of fire and explosions!
- ▶ Have repairs been made only by experts, e. g. the producer's service.
Use original spare parts only.
- ▶ Improperly repaired devices pose a hazard for the user.
- ▶ Use the socket of the vacuum device only for the purposes defined in the instruction manual.
- ▶ In case of any inappropriate usage, improper operation or repair, the producer shall be exempt from liability.
- ▶ Do not use any damaged extension lines.



DANGER! – WARNING!

- ▶ If the connector line of the vacuum device has been damaged, it must be replaced with a special connector line which is available from the producer or their service.
- ▶ Electric brushes: Do not allow the rotating brushes to get into contact with the power connection line.
- ▶ The voltage on the type sign must correspond to the grid voltage.
- ▶ After every use and before any maintenance, switch off the vacuum device and pull the power plug.
- ▶ Pull on the plug only, not on the line.
- ▶ Never plug or pull the power plug with wet hands.
- ▶ The socket must be secured via a household fuse with a suitable current rating.
- ▶ Never open the vacuum device outdoors in rain or storm.



Caution

- ▶ Persons (including children) who are, due to their physical, sensory or intellectual abilities or lack of experience or knowledge, unable to safely use the vacuum device should not use it without supervision or instruction by a responsible person.
- ▶ Particular caution is advised with children, elderly or infirm persons.
- ▶ Do not point nozzle, tube or hose at people or animals.
- ▶ Use only the brushes supplied with the vacuum device or defined in the instruction manual. Use of any other brushes may pose a safety hazard.
- ▶ Clean and disinfect the vacuum device immediately after use to prevent microbial contamination due to long-term failure to clean it, especially when using the device in food-processing.
- ▶ Do not use any steam jets or high-pressure cleaners for cleaning.
- ▶ Acids, acetone and solvents may corrode parts of the vacuum device.
- ▶ Do not leave the device without supervision. In case of longer interruptions of work, pull the power plug.
- ▶ Do not clean filter cassettes with compressed air.

Read the operating manual carefully before starting to use the vacuum cleaner. It provides important instructions for the operation, safety, care and maintenance. Keep the operating manual in a safe place and, in case you sell the unit, hand it on to the next owner.

The manufacturer reserves the right to carry out modifications to the design and equipment. Any other work not covered by this operating manual must not be carried out.



3 Before use

- ▶▶ When unpacking, check that the delivery is complete and that there is no transport damage.
- ▶▶ Before using, the operators should be provided with information, instructions and training for the use of the vacuum cleaner and the substances that it is to be used for, including the safe procedure for the removal of the gathered material.

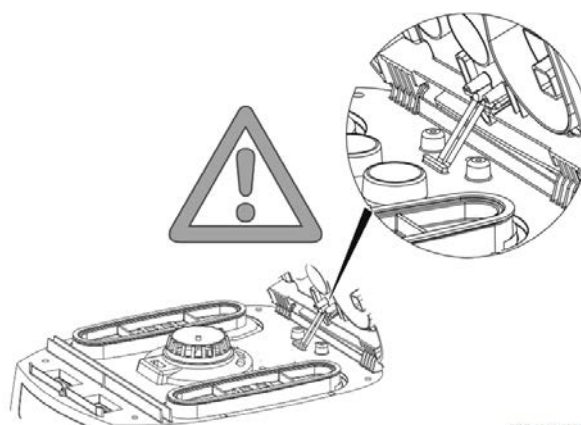

B0C-1114-0002

2 Indicator and operating elements

Select from the following functions and settings:

0		Vacuum cleaner is switched off	-Plug socket current-conducting
I		Vacuum cleaner is running	-Plug socket current-conducting -Automatic shaker function off
IR		Vacuum cleaner is running	-Plug socket current-conducting -Automatic shaker function on
AR		Ready for operation	-Plug socket current-conducting -Automatic shaker function on - The vacuum cleaner is switched on and off via the connected electrical tool at the plug socket.
		Automatic shaker function	-- During suction, the folding filter cassettes are cleaned alternately when a specific negative pressure is reached, at which there is still adequate suction air.
		Fill level indicator	-- When the container is full and/or there is a blockage in the suction hose, the full indicator lights up, an acoustic signal is also emitted.
		Setting the suction hose diameter	-- Determine the maximum negative pressure for automatic shaking.

4 Commissioning

4.1 Switching on and off

The plug socket on the vacuum cleaner will always be live when the mains plug is plugged in, irrespectively of the position of the switch



Caution!

Electric tools and compressed air tools must be switched off when they are connected



Information

If the switch is in the >0< position, the plug socket on the vacuum cleaner can be used as an extension lead.

! Connection value: Vacuum cleaner + connected unit, maximum 16 A.

▶▶ Insert the plug into socket

> 0 < Vacuum cleaner is switched off

> I < Vacuum cleaner switched on without Shaker function

> IR < Vacuum cleaner switched on with Automatic shaker function

> AR < Vacuum cleaner on standby

The vacuum cleaner only switches on when the tool is switched on.

After the tool is switched off, the vacuum cleaner runs on for approx. 10 sec to prevent any residue from collecting in the hose.

▶▶ Set the vacuum cleaner to the switch position >0<.

▶▶ Pull out the plug after you have finished.

▶▶ Fix the suction hose in the accessory storage location on the back of the container for storage.

▶▶ The ends of the hose can be pushed into each other to prevent particles of dirt from coming out.



Caution!

Selector switch for minimum material flow (horn and light) on the vacuum cleaners:

In the modes >AR< and >IR< the following setting is made, depending on the diameter of the hose:

Hose inner diameter	Selection switch (position 8, page 2)
Ø 50 mm	35 (Blastrac dust hose)
Ø 35 mm	35 (70 m ³ /hr)
Ø 27 mm	27 (40 m ³ /hr)

No speed regulation is carried out. The vacuum cleaner always runs at max. speed.

▶▶ Push the plug of the vacuum cleaner into the plug socket.

▶▶ Set the switch for normal operation without shaker function to "I" and set it to "IR" for normal operation with shaker function and to "AR" for standby mode.

⏏ The vacuum cleaner is ready for suction.

▶▶ After vacuum cleaning, set the switch to "O".

⏏ The vacuum cleaner is switched off.

▶▶ Pull the mains plug of the vacuum cleaner out of the plug socket.

▶▶ Secure the mains cable.

▶▶ Remove the electric/compressed air tool.

5 Operating modes

▶▶ When using the grip handle you can adapt the suction performance by using the slider to control access of air into the hose.

5.1 Dry vacuum cleaning

You should only use the vacuum cleaner with a dry filter and appropriate accessories to prevent dust from accumulating and forming encrustations. When using the vacuum cleaner to remove soot, cement, plaster, flour or similar dust we recommend using fleece filter bags. Always use filter bags in combination with folding filter cassettes.



Information

M, H and H Asbestos class vacuum cleaners should be preferably used as dry vacuum cleaners.

5.2 Wet vacuum cleaning



Caution!

Switch the vacuum cleaner off immediately if foam or liquid starts to come out.

▶▶ Empty the container and, if necessary, clean the folding filter cassette.



Information

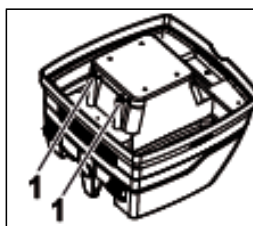

Clean the water level sensors (1) regularly and examine for signs of damage.

- ▷ Wet vacuum cleaning without paper filter bags. The folding filter cassettes are designed for wet vacuum cleaning. The fitted sensor switches the motor off when the container is full. The handling of the vacuum cleaner can be compromised by a full container.
- ▷ Empty the vacuum cleaner (see "7 Emptying the container").



Caution

If the vacuum cleaner is not switched off, the re-start protection unit remains operative. Only after switching off and re-starting is the vacuum cleaner ready for use again.

- ▷ Remove the suction hose from the liquid before emptying.
- ▷ After switching off, a small quantity of water can flow back out of the hose, as a result of the high suction level and the favourable flow condition in the container.
- ▷ If you use it as a dry vacuum cleaner, you must insert dry filters.



Information

If you change between dry and wet vacuum cleaning frequently, we recommend using a second set of filters, preferably polyester folding filter cassettes.

6 Permanent filter cleaning

The vacuum cleaner is fitted with an electromagnetic filter cleaning unit which can be used to shake the dust off the folding filter cassettes. The folding filter cassettes are cleaned alternately so that continuous working can be guaranteed.



- Continuous monitoring of the filter filling level through differential pressure measurement, for an absolutely precise on-demand filter cleaning during the operation
- Thereby constant high air flow cleaning guaranteed during the operation, even for critical types of dust

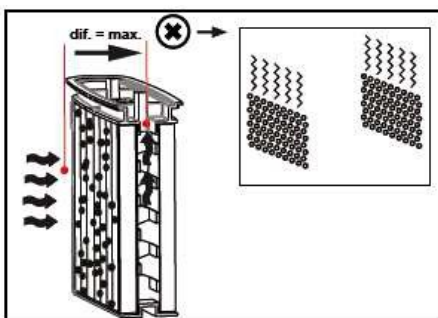

7 Emptying the container



Information

Only permitted for dust with AGW's > 1mg/m³ !

- Switch the vacuum cleaner off, pull the mains plug out.
- ▷ Open the latches.
- ▷ Remove the cover and suction hose from the container.
- ▷ Empty the container by pouring out.

7.1 Dispose of the fleece filter bag

- ▷ Pull the mains plug out.
- ▷ Fit mouth protection.
- ▷ Remove suction hose, close off the suction spigot with the plug.
- ▷ Open the side latches, remove the top section.
- ▷ Carefully pull the flange off the suction spigot and close off the flange.
- ▷ Dispose of the vacuumed up material in accordance with legal requirements.

7.2 Dispose of the PE emptying and disposal bag

- ▷ PE emptying and disposal bag: Switch the vacuum cleaner on, shake the folding filter cassettes. Switch off the vacuum cleaner.
- ▷ Fit mouth protection.
- ▷ Remove suction hose, close off the suction spigot with a plug.
- ▷ Open the side latches, remove the top section. Before setting aside the top section, switch to >IR< position, to draw up any floating dust which may exist.
- ▷ Close off the PE emptying and disposal bag carefully with the tie-wrap provided.
- ▷ Carefully pull the flange off the suction spigot and close it off.
- ▷ Remove the PE emptying and disposal bag carefully from the container.
- ▷ Dispose of the vacuumed up material in accordance with legal requirements.

7.3 Insert fleece filter bag

- NOTE - Only use fleece filter bags for dry vacuum cleaning.
- ▷ Slide the flange completely over the suction aperture

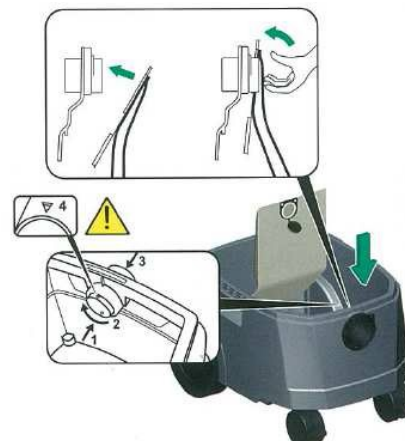

Operating the rotary slider

- ▶▶ Push the rotary slider from the inside to the outside, turn through 180° (see mark) and then push inwards again from the outside through the suction spigot
- ▶▶ Place the rotary slider in the suction aperture with the mark ▲ pointing upwards.

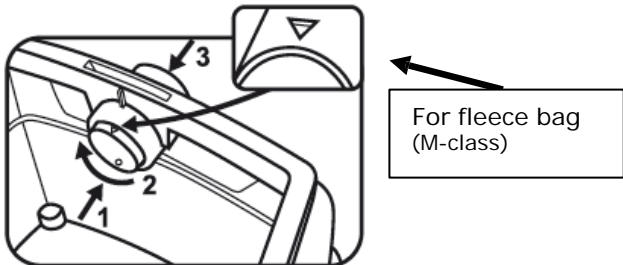

- ▶▶ Place the upper section on the container and close the side latches.

7.4 Insert PE emptying and disposal bag

- ▶▶ Slide the flange completely over the suction aperture and place the upper bag opening over the edge of the container.

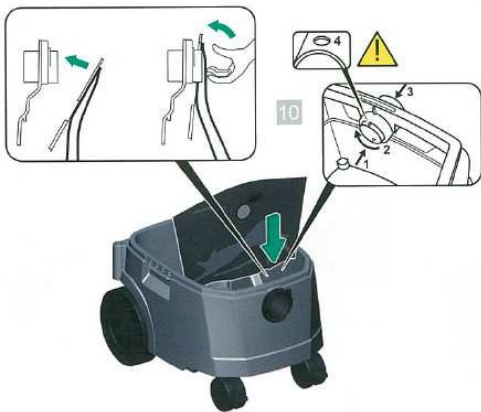

Operating the rotary slider

- ▶▶ Push the rotary slider from the inside to the outside, turn through 180° (see mark) and then push inwards again from the outside through the suction spigot
- ▶▶ Place the rotary slider in the suction aperture with the mark ● pointing upwards.

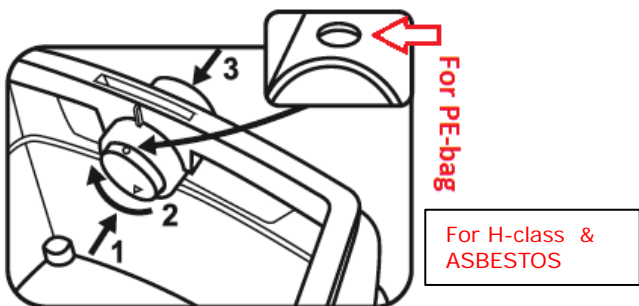

- ▶▶ Place the upper section on the container and close the side latches.

8 Changing the filter

8.1 Changing the folding filter

- ▶▶ Shake the folding filter cassettes before changing them.
- ▶▶ Turn the lock on the latch through 90° in a counter-clockwise direction with a coin or similar object and push the latch to the rear.
- ▶▶ Fold the hood up
- ▶▶ Immediately isolate the folding filter cassettes that you have removed in a dust-tight plastic bag and dispose of properly in accordance with the regulations.
- ▶▶ Insert new folding filter cassettes.
- ▶▶ Lift the locking bracket up, fold the hood down and click in place with light pressure.

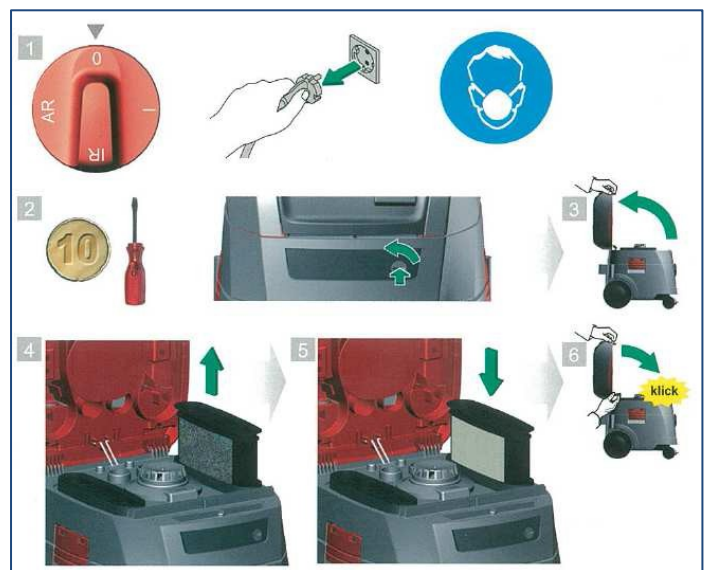

9 Changing the motor protection filter

- If the motor protection filter is contaminated this indicates defective filter cassettes.
- ▶▶ Replacing the folding filter cassettes.
 - ▶▶ Replace the motor protection filter or wash the motor protection filter under flowing water, dry and re-insert.

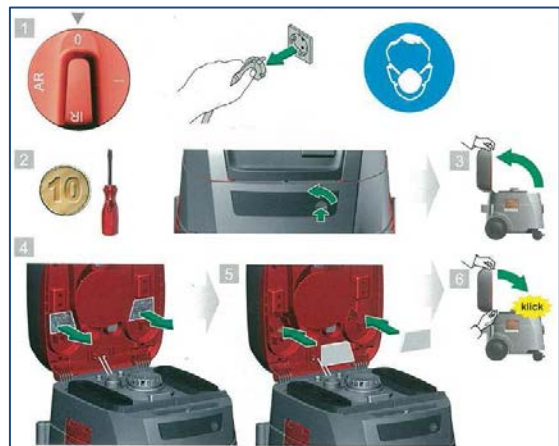

10 Transport

- ▷▷ Insert the closing plug of the vacuum cleaner into the suction aperture.
- ▷▷ The motor head must be securely fixed to the container (close the latches).
- ▷▷ Place the accessories in a suitable plastic bag and seal the plastic bag or place it in the tool storage compartment.
- ▷▷ Plug the ends of the suction hose into each other. (3)
- ▷▷ Place the hose around the vacuum cleaner and clamp onto the handle.



11 Maintenance

-Switch the vacuum cleaner off and pull out the mains plug before any maintenance work.
For maintenance by the user, the vacuum cleaner must be

- dismantled,
- cleaned and
- maintained,

as far as possible without creating any danger to the maintenance personnel or other.

Precautionary measures

Suitable precautionary measures include

- Cleaning before dismantling,
- Provide local filtered positive ventilation where the vacuum cleaner is to be dismantled,
- Clean the maintenance area and
- suitable personal protection equipment.



Caution

Precautionary measures with vacuum cleaners class H and M

The outside of the vacuum cleaner should be cleaned and wiped down or should be treated with a sealing agent before being removed from the dangerous area. All parts of the vacuum cleaner must be considered to be contaminated when they are removed from the danger area and suitable handling must be used to prevent dust distribution.

Contaminated items

When carrying out maintenance or repair work, all contaminated items which have not been adequately cleaned must be disposed of. Such items must be disposed of in impermeable bags in accordance with the applicable regulations concerning the disposal of such waste.



Information

Testing the effectiveness of the vacuum cleaner

NOTE: In addition, the effectiveness of the vacuum cleaner class **H** must be checked at least once a year. There must be an adequate *air exchange rate L* in the room if the exhaust air returns to the room. Further information can be taken from your national regulations. If the suction of the vacuum cleaner reduces and the cleaning procedure of the folding filter cassettes increases, the suction performance is not adequate (provided that the container is empty and the fleece filter bag has been replaced) then it is necessary to replace the folding filter cassettes.

11.1 Cleaning

Acids, alkalis and solvents can corrode the vacuum cleaner parts.

- ▷▷ Clean the container and accessories with water.
- ▷▷ Wipe the top section with a damp cloth.
- ▷▷ Allow the container and accessories to dry.

11.2 Repair



DANGER! – WARNING!

- ▷▷ Inappropriately repaired vacuum cleaners present a danger to the operator.
- ▷▷ Have repairs carried out by specialists, e. g. customer service. Use only genuine spare parts.

12 First aid in the event of a fault



Information

Fault	Possible cause	Remedy
Reduction in suction	Filter contaminated	Clean
	fleece filter full	Change
	Container full	Empty
	Nozzle, pipes or hose blocked	Clean
Vacuum cleaner will not start	Mains plug plugged in?	Set to "I" or "IR"
	Mains power missing?	
	Mains cable OK?	
	Cover closed properly?	
	Water sensor switched off?	
	Vacuum cleaner in readiness for operation "AR" ?	
The vacuum cleaner does not start When the tool is switched on in the 'AR'mode	Is the mains plug of the unit in the plug socket?	Put the mains plug in the vacuum cleaner plug socket
	Solenoid valve of compressed air automatic switch-on* contaminated?	Flush the compressed air automatic switch-on* with alcohol
PE emptying and disposal bag is sucked against the filter	Position of rotary slider incorrect	Set rotary slider to ● position (see 6.4)
Vacuum cleaner classes M or H: with inserted paper filter dust in filter	Position of rotary slider incorrect	Set rotary slider to ▲ position (see 6.3)

Do not take any other action and contact the central customer service workshop.

13 Genuine accessories

NOTE: Always use genuine accessories.

Article designation	Properties / Material	Order quantity
M-class filter cartridge	Polyester material, BGIA class M approved Ordernr. ES423159 Art.-Nr. M/535 777	Set of 2
H-class filter cartridge	3 layer filter cassette , BGIA class H-14 approved Ordernr. ES428956 Art.-Nr. H/HEPA 551029	Set of 2
Fleece Filter-bag	For 30 Liter plastic container, BGIA class M approved Ordernr. ES435305	Set of 5
PE emptying and disposal bag	For hazardous dusts Ordernr. E06260	Set of 5
PE emptying and disposal bag ASBESTOS	only for vacuum cleaner H ASBESTOS Ordernr. ES430249	Set of 5

Additional accessories can be found in the special accessory list which can be obtained on request from the Blastrac team on the internet: www.Blastrac.eu.

14 Technical Data

	BDC-1114PM BDC-1114PH 230V	BDC-1114PM BDC-1114PH 110V-50Hz	BDC-1114PM BDC-1114PH 120V-60Hz
Power consumption	1,2 kW	1,2 kW	1,2 kW
Max. power	1,4 kW	1,4 kW	1,4 kW
Electrical connection / frequency	220-240V / 50-60 Hz	100-120V / 50 Hz	100-120V / 60 Hz
Air flow at hose end	140 m3/hr/SE	140 m3/hr/SE	140 m3/hr/SE
Air flow at blower	230 m3/hr/SE	230 m3/hr/SE	230 m3/hr/SE
Under pressure at hose end	225 hPa/SE	225 hPa/SE	225 hPa/SE
Under pressure at blower	259 hPa/SE	259 hPa/SE	259 hPa/SE
Weight	17.1 kg	17.1 kg	17.1 kg
Noise level	Up to 69.5 dB(A)	Up to 69.5 dB(A)	Up to 69.5 dB(A)

	BDC-1114 PH CA ASBESTOS 230V	BDC-1114 PH CA ASBESTOS 110V-50Hz	BDC-1114 PH CA ASBESTOS 120V-60Hz
Power consumption	1,2 kW	1,2 kW	1,2 kW
Max. power	1,2 kW	1,2 kW	1,2 kW
Electrical connection / frequency	220-240V / 50-60 Hz	100-120V / 50 Hz	100-120V / 60 Hz
Air flow at hose end	140 m3/hr/SE	140 m3/hr/SE	140 m3/hr/SE
Air flow at blower	230 m3/hr/SE	230 m3/hr/SE	230 m3/hr/SE
Under pressure at hose end	225 hPa/SE	225 hPa/SE	225 hPa/SE
Under pressure at blower	259 hPa/SE	259 hPa/SE	259 hPa/SE
Weight	17.1 kg	17.1 kg	17.1 kg
Noise level	Up to 69.5 dB(A)	Up to 69.5 dB(A)	Up to 69.5 dB(A)

Dimensions for all models (LxBxH): 53 cm x 40 cm x 55 cm.
Connection line on vacuum cleaners with plug socket:
HO7RN-F 3x1,5

15 Tests and approvals

Electro-technical tests must be carried out in accordance with the accident prevention regulations (BGV A3) and in accordance with DIN VDE 0701 Part 1 and Part 3. These tests are required in accordance with DIN VDE 0702 at regular intervals and after repair or modification. A dust-technical check must be carried out at least once a year, or more frequently as may be specified by national requirements, by the manufacturer or a trained person, e. g. for damage to the filter, dust-tightness of the vacuum cleaner, function of the monitoring equipment. The vacuum cleaners are successfully tested in accordance with IEC/EN 60335-2-69 including annex AA.

Information

Old equipment contains valuable materials which are designed for re-processing. **The vacuum cleaners must not be thrown away in the normal household waste**, but should be disposed of at a suitable proper collection system, e. g. via your communal disposal location.





Original version.

EC DECLARATION OF CONFORMITY

in accordance with Appendix II sub A of Directive 2006/42/EC

We,

BLASTRAC B.V.
Utrechthaven 12
NL - 3433 PN NIEUWEGEIN
The Netherlands

Declare under our sole responsibility that the dust collecting machine as described below,

Model: BDC-1114XXXX

Serial number: XXXXX XXXXX

satisfies the conditions set out in the:

Machinery Directive	(2006/42/EC);
ROHS Directive	(2011/65/EU);
EMC Directive	(2004/108/EC);

Where appropriate, are in conformity with the following harmonized standards:

EN 60335-1:2002+A15:2011
EN 60335-2-69:2009
EN 62233 Ber.1:2008
EN ISO 12100:2010
EN 55014-1:2006+A1:2009
EN 61000-3-2:2006+A2:2009
EN 61000-3-3:2008
EN 55014-2:1997+A2:2008
EN 50581:2012

In case of changes to the machine without our written authorization this declaration loses its validity.

Nieuwegein 15-11-2013

Michiel Kalisvaart

Michiel Kalisvaart
Operational Manager

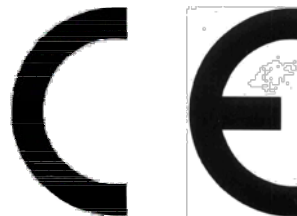

Inspection comments

Inspection before initial operation on:	_____
By:	_____
Date of initial operation:	_____

Recurring inspections

Date	Findings	Repairs / Cleaning	Test on	By*

Other comments:



SERVICE MANUAL BDC-1114

VERSION 1.5

Index

1. Assembly plans & Spare parts	04
Contact	07





1. Assembly plans & Spare parts



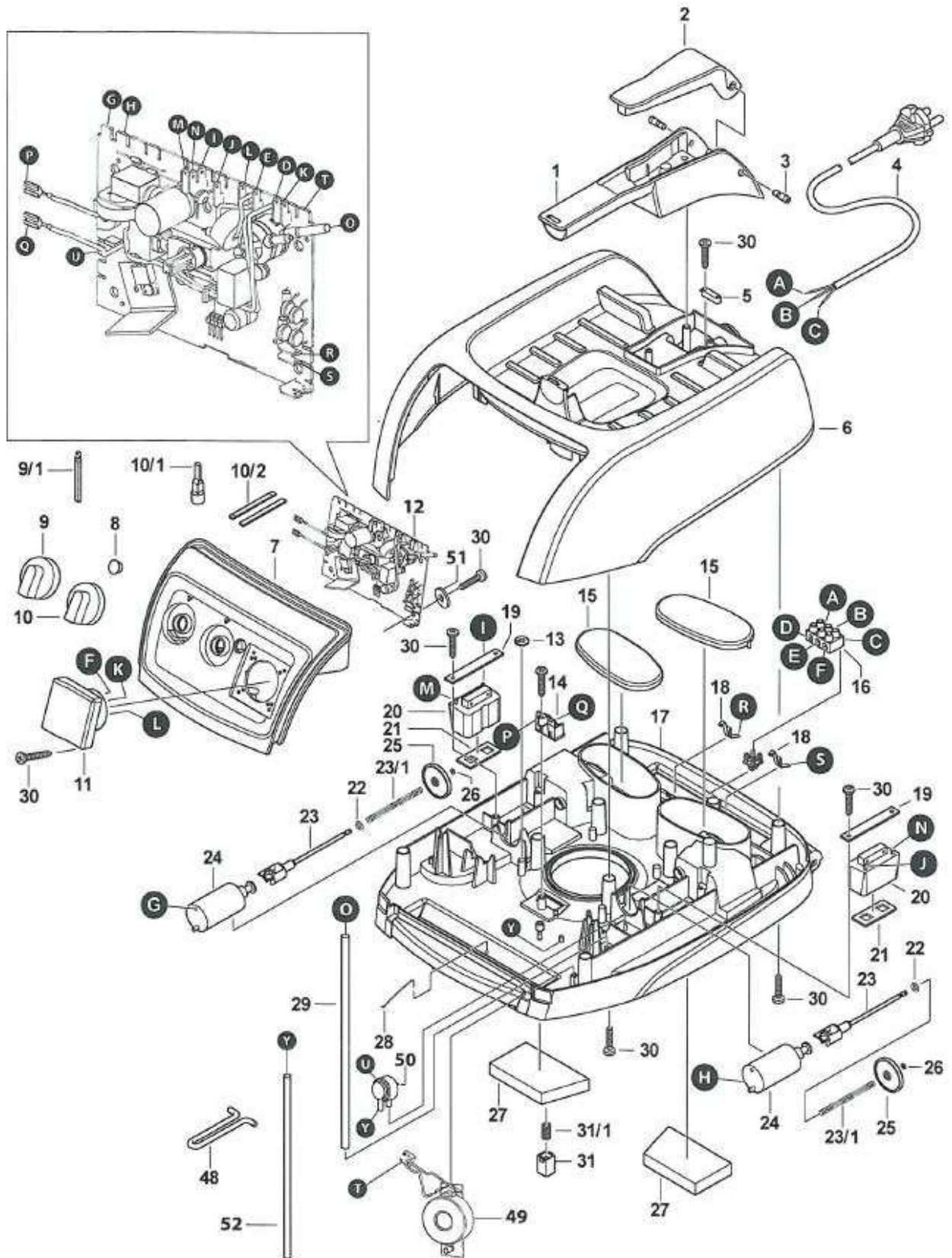



Item	Part number	Description	Qty.
1+2+3	ES407937	Handle, cover plate & bolt	1
2	ES512761	Handle	1
3	ES407944	Bolt	2
4	ES590448	Power cord 230V / 50-60Hz	1
4	ES552866	Power cord 110V / 60Hz (USA)	1
4	ES581910	Power cord 110V / 50Hz (UK)	1
5	ES531137	Strain relief clamp	1
6	ES510484	Cover housing	1
7+8	ES408019	Front plate + lens	1
8	ES538945	Lens	1
9	ES403007	Adjusting knob M/H	1
9/1	ES512501	Kob spindel long	1
10	ES402864	Switch knob	1
10/1	ES512471	Knob spindel short	1
10/2	ES408453	Switch spring	2
11	ES546858	Power tool plug socket 230V / 50-60Hz	1
	ES548975	Power tool plug socket 110V / 60Hz (USA)	
	ES516776	Power tool plug socket 110V / 50Hz (UK)	
12+50+51+52	ES432694	Electronic plate + pressure switch + insulating disc + vacuum tube	1
13	ES408460	Holding disc	4
14	ES417707	Motor plug socket	1
15	ES408040	Cover	2
16	ES506104	Luster terminal	1
17	ES510408	Carrier plate	1
18	ES408484	Contact bow	2
19	ES408613	Holding bracket	2
20	ES690025	Vibrating magnet	1
21	ES408620	Sealing	2
22+26	ES408088	O-ring + safety ring	2
23	ES511184	Coupling	1
24	ES613628	Pull magnet	1
23/1+25+26	ES408101	Compression spring + valve disc + safety ring	1
27+27/1	ES408200	Motor protection filter + noise insulation	2
28	ES535500	Contact wire	1
29	ES549262	Vacuum tube	1
30	ES408705	Spax screw	35
31+31/1	ES408736	Pressure piece + pressure spring	4
48	ES513485	Brace support	1
49	ES613222	Signal horn	1

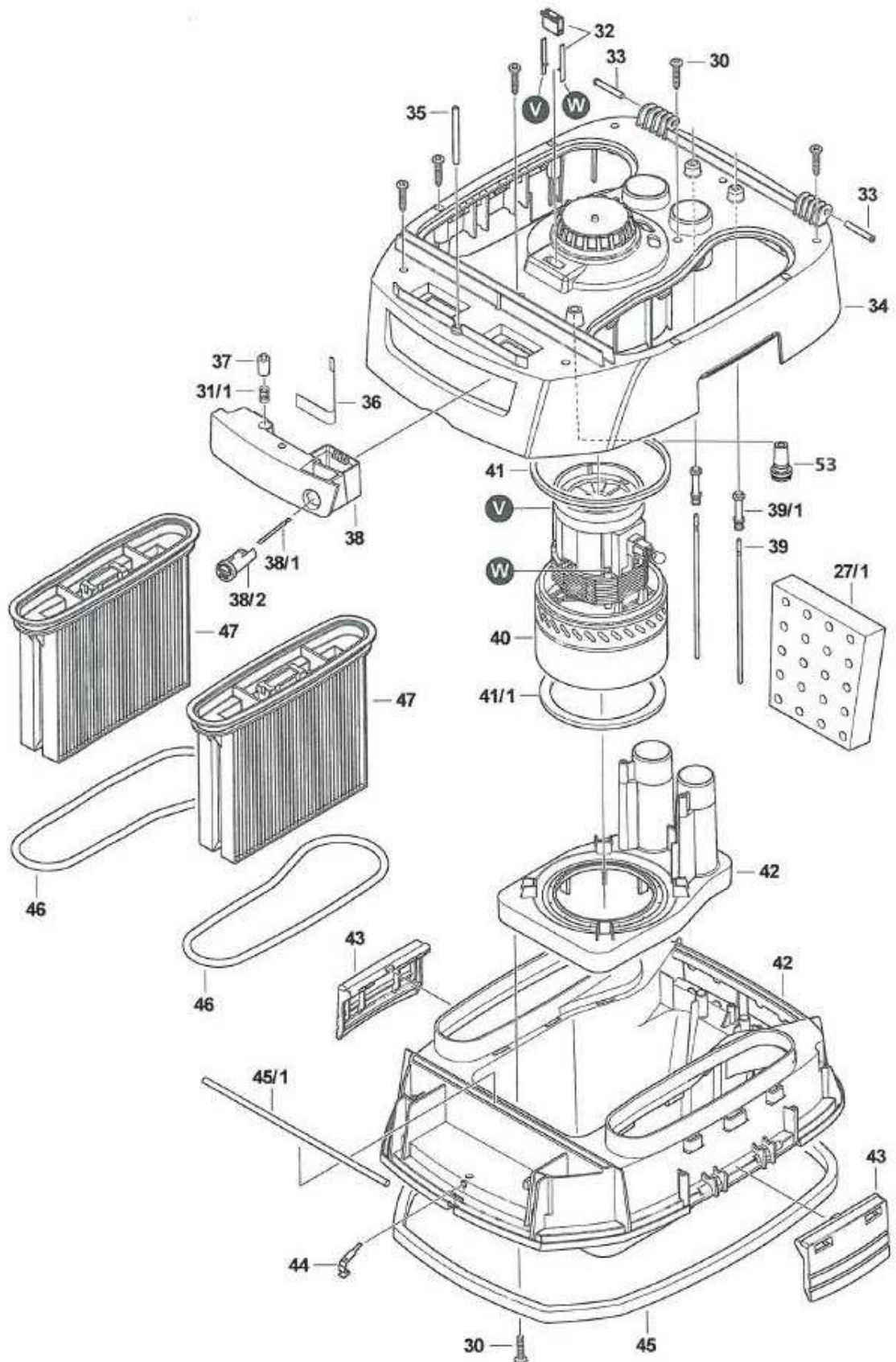

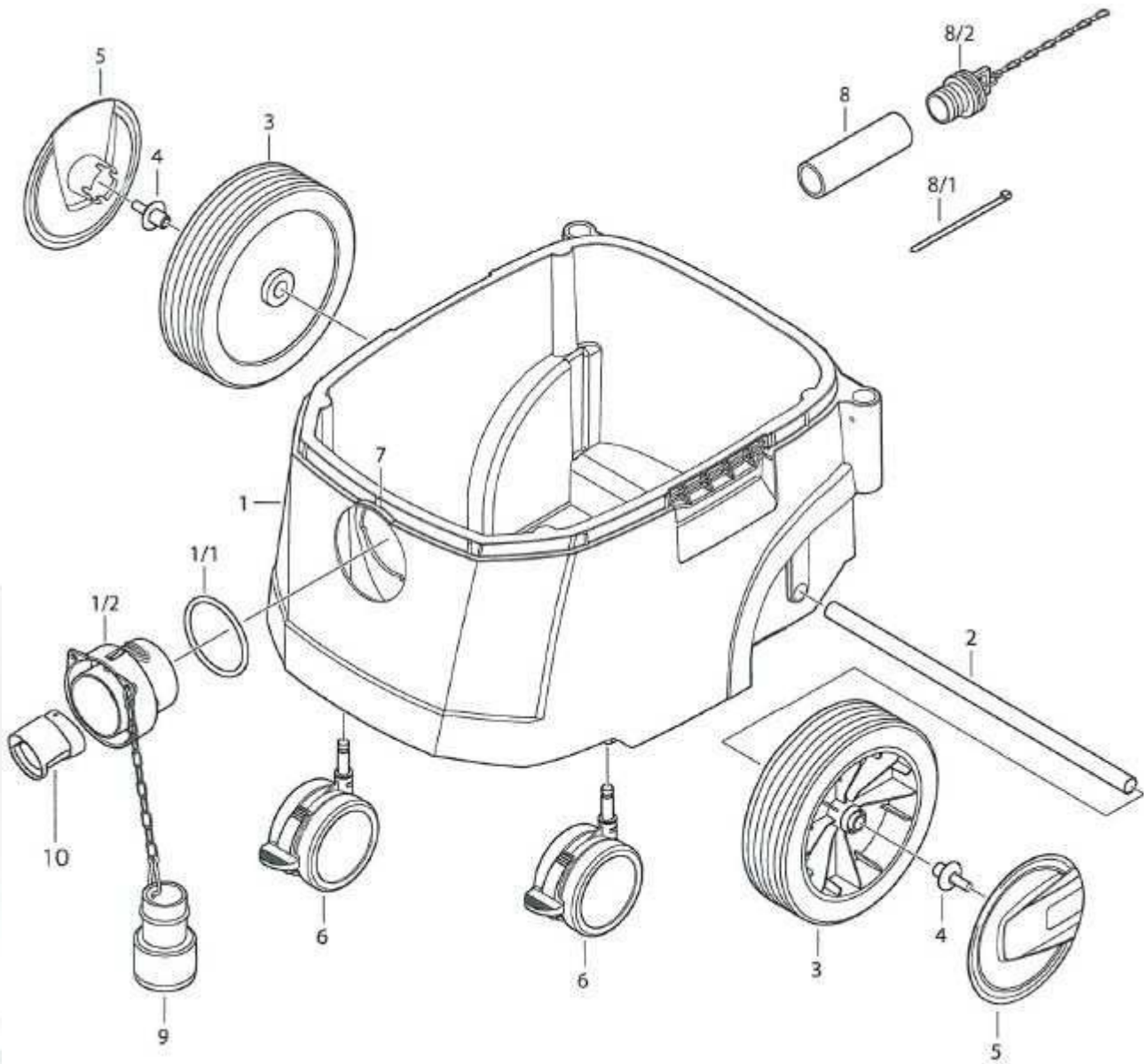

Item	Part number	Description	Qty
1	ES011851	Container	1
2	ES511399	Axle	1
3+4+5	ES408347	Wheel complete	2
4	ES408903	Wheel plug	2
5	ES408941	Wheel over	2
6	ES408408	Castor wheel	2
7	ES512549	Discharge bolt	1
8	ES408958	Drain set	1
9	ES406930	Container stopper	1
10	ES509037	Rotary valve	1



13201 North Santa Fe Avenue • Oklahoma City, OK 73114 • Ph: 800-256-3440 • F: 405-478-8608 blastrac.com

Product Warranty

Standard Equipment Products:

Blastrac warrants its Blastrac Standard Equipment Products against defects in quality of material and workmanship, under normal and proper use for a period of **1 Year** from the date of delivery, as noted on the returned warranty registration card, or, in the case of **Rental Fleet Machines, 180 Days** from the date of assignment to Rental Fleet. This warranty is non-transferable and is extended to machines purchased and entered into the normal service of surface preparation by a recognized professional or qualified contractor. Blastrac makes this warranty only to the buyer who purchases the products directly from Blastrac or its Authorized Distributor. This warranty does not include expendable parts such as, but not limited to, blades, blast wheels, wear plates, liners, seals, and electrical components. All purchased parts utilized in the manufacture will be honored to the original manufacturer's specified warranty.

If the buyer does not return the warranty card or register the product online at www.blastrac.com within 30 days after taking delivery of Blastrac Standard Equipment Products, the warranty period is limited to 6 months from the date of delivery noted on shipping receipt.

Hand Tool Products:

Blastrac warrants its BLASTRAC Hand Tool Products, including hand grinders and accessories, against defects in material and workmanship under normal and proper use for a period of **90 days** from the date of delivery or, in the case of Rental Fleet Machines, from the date of assignment to a Rental Fleet. Blastrac makes this warranty only to the buyer who purchases the products directly from Blastrac or its authorized distributor. This warranty does not include expendable parts such as blades.

If the buyer does not return the warranty card, or register online at www.blastrac.com within 15 days after taking delivery of Blastrac Hand Tool Products, the warranty period is limited to 30 days from the date of delivery noted on shipping receipt.

WARRANTY TERMS AND CONDITIONS:

1. Blastrac's obligation under this warranty is limited to the replacement or repair, at Blastrac's option, of products and does not include, labor, the cost of transportation, loss of operating time, or normal maintenance services.
2. This warranty does not apply to failure occurring as a result of abuse, misuse, negligence, corrosion, erosion, normal wear and tear, alterations or modifications made to products without the express written consent of Blastrac.
3. The buyer must submit all warranty claims no later than thirty (30) days after buyer becomes aware of the basis for any such claim, or should have become aware of the basis for any such claim in the exercise of reasonable diligence.

To return parts for warranty consideration, please call Blastrac Customer Service at **800-256-3440**. Your customer service representative will obtain the necessary information to complete the Blastrac Returned Merchandise Authorization (RMA) Form. Blastrac will then send the RMA form to the customer authorizing the return of the parts for warranty evaluation. The parts must be received within sixty (60) days following the RMA origination date or the warranty claim will be denied. Once the parts are received they will be evaluated for warranty.

If the customer cannot wait for the evaluation/replacement of the parts during this process, the customer must issue a new purchase order to Blastrac for the replacement parts before they can be shipped. Once the evaluation process is complete and parts are deemed a valid warranty claim, a credit will be issued against this invoice.

4. The buyer may not return Blastrac products without written authorization to do so through a Blastrac RMA.

5. Blastrac reserves the right to inspect and determine the scope of its warranty responsibilities for any returned Blastrac products.

6. Blastrac makes no warranty with respect to accessories it does not manufacture, including but not limited to, engines, motors, batteries, tires and all other parts. See component manufacture warranty.

7. Blastrac reserves the right to make product changes or improvements without prior notice and without undertaking any obligation for such changes or improvements on previously sold products.

8. The above warranty conditions can only be altered by Blastrac. Blastrac must confirm alterations in writing for each specific transaction.

9. Blastrac reserves the right to modify this warranty for used or demo products on an individual transaction basis. Blastrac will include warranty modifications on its invoices for used or demo products.

10. BLASTRAC DOES NOT AUTHORIZE ANY PERSON, REPRESENTATIVE, SERVICE OR SALES OUTLET TO MAKE ANY WARRANTY DIFFERENT FROM THIS PRODUCT WARRANTY.

11. EXCEPT FOR ITS PRODUCT REPAIR OR REPLACEMENT OBLGATIONS DESCRIBED IN THIS PRODUCT WARRANTY, UNDER NO CIRCUMSTANCES SHALL BLASTRAC BE LIABLE TO THE BUYER, OR ANY OTHER PERSON, FOR ANY DIRECT, INCIDENTAL, OR CONSEQUENTIAL DAMAGES RESULTING FROM THE USE OF THE BLASTRAC PRODUCT, OR FOR ANY SPECIAL OR CONSEQUENTIAL DAMAGES OF ANY CHARACTER, INCLUDING WITHOUT LIMITATIONS, DAMAGES FOR ANY LOSS OF GOODWILL, WORK STOPPAGE, OR ANY AND ALL OTHER COMMERCIAL DAMAGES OR LOSSES.

12. BLASTRAC MAKES NO OTHER PRODUCT WARRANTIES, EXPRESS OR IMPLIED, INCLUDING, BUT NOT LIMITED TO, THE IMPLIED WARRANTIES OF MERCHANTABILITY AND FITNESS FOR A PARTICULAR PURPOSE.



IMPORTANT!

TO THE DELIVERING DISTRIBUTOR OR END USER

To ensure the proper warranty coverage is extended to the owner of this machine, fill in the necessary information below **COMPLETELY** and **ACCURATELY** and retain for your records. **Go to www.blastrac.com and register online.** Click on the Register icon in the left column of the homepage, and fill out the product registration form with the same information that will be recorded here.

The warranty period will start upon the delivery date of the machine.

The distributor or the end user must provide the machine warranty information when the machine is delivered. Registration of the machine will extend the warranty period from the recorded delivery date entered with product registration. **Failure to comply will make any and all warranties on the equipment void after 6 months.**

OWNER/END USER'S REFERENCE INFORMATION

Delivery Date _____	Machine Model No. _____
Delivering Distributor's Name and Address _____	Machine Serial No. _____
_____	Modifications _____
_____	_____
_____	_____
_____	_____
_____	_____

Signature of Delivering Distributor's Representative

Blastrac is a registered trademark of Blastrac,NA
Fold and Detach Here if Mailing

Warranty Registration

IMPORTANT! To ensure that your Blastrac® machine is covered under warranty, please provide the information recorded here by registering online at blastrac.com, or complete this page and fax to 866-485-1046, or if you prefer, detach and mail to:

Blastrac, 13201 North Santa Fe Avenue, Oklahoma City, OK 73114-9901

(Please print legibly)

Company _____

Address _____

City, State, & Zip _____

Telephone No. _____ Contact Person _____

Date of Purchase _____ Date Received _____

Machine Model No. _____ Serial No. _____

Distributor Name _____

End User Name _____

End User E-mail _____



Contact

Blastrac Canada
5125 Timberlea Blvd.
Mississauga, Ontario, Canada L4W 2S3
Tel: 1-866-669-6643
Fax: 866-669-6644
www.blastrac.ca

